

VideoTelephone Booths „Slat“

In addition to excellent technical equipment and good workplace lighting, it is above all the room acoustics that help us to successfully conduct a demanding video or telephone consultation. After all, the conversations place high demands on the room acoustics, especially on speech intelligibility.

With the „Slat“ model series, consisting of two different model variants in three sizes each, consultation islands become attractive eye-catchers and sought-after workplaces in open office zones. Both variants are equipped with an acoustically open slat wall in decor (according to the AOS collection) over a width of 910 mm on the access side. While variant 1 has completely closed walls on three sides, variant 2 has partial glazing on one side from a height of 1400 mm. What the two variants have in common is the modular construction and the highly sound-absorbing acoustic walls with a total height of 1800 mm. The absorbers used have their strengths in the frequency range of human speech and thus produce the best acoustic results while at the same time preventing direct sound transmission. A continuous wall fabric division at a height of 1000 mm guarantees the use of 17 different fabric collections and offers the possibility of different colour assignments. The corner and cover profiles made of anodised aluminium (EV1) are optionally available powder-coated according to RAL.

Supplied disassembled into individual wall elements for assembly on site.



Model variants Slat

Slat V1



Slat V2



Model sizes

W.180

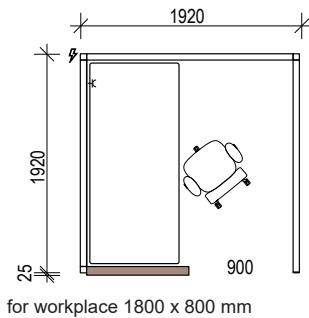

W.160

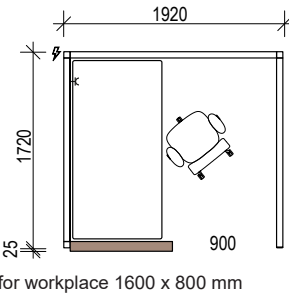

W.140

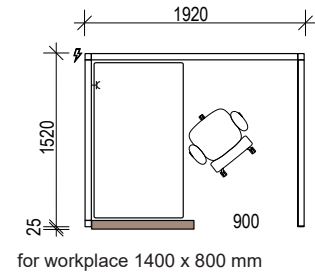

! Safety note: Use with electronic or gas spring height adjustment of the work table is only possible after consultation / on request, special dimensions are mandatory.

Height	1800 mm
Width (outside)	1920 mm
Clear inside width	1810 mm
Depth (outside)	1920 mm
Clear inside depth	1810 mm

Height	1800 mm
Width (outside)	1720 mm
Clear inside width	1610 mm
Depth (outside)	1920 mm
Clear inside depth	1810 mm

Height	1800 mm
Width (outside)	1520 mm
Clear inside width	1410 mm
Depth (outside)	1920 mm
Clear inside depth	1810 mm

For all model variants, the wall fabric pitch applies at a height of 1000 mm.

Standard equipment

Power / data supply, \varnothing 120mm, 1x safety socket, 2x USB 3.0 A socket, surface=stainless steel look, lockable integrated in front wall, 600mm from floor (further connection variants after technical clarification)

Electric post with removable cover for on-site installation of power and data cables

Side panel (width 1810 mm) magnetic on inside with substructure (height 1000 to 1800 mm or up to 1400 mm Open V2, Slat V2, TopLED V3)

Walls with magnetic substructure are supplied including 2 „Steel 25“ office magnets

Requirements: Magnets with medium holding force (up to 8 kg), diameter 25 mm required

Optional equipment

Work table height adjustable, grid height adjustment from 650 to 850mm height, worktop 25mm decor with cable outlet box on the right

Digital print on rear panel (inside) from height 1000 mm up to height approx. 1800 mm

Preparation for wall-mounted monitor, substructure incl. empty conduit and data outlet box

Optional walls with an acoustic filling made of sheep's wool - 100% sustainable.

Wall construction 55 mm

with increased sound insulation

Sound absorption coefficient α_p per DIN EN ISO 354

125 Hz	α_p 0,33
250 Hz	α_p 0,59
500 Hz	α_p 0,77
1000 Hz	α_p 0,87
2000 Hz	α_p 0,94
4000 Hz	α_p 0,96

Rated sound absorption coefficient α_w 0,80 (H)
DIN EN ISO 354 test certificate

Rated sound reduction index R_w 32 (dB)
DIN EN ISO 717-1